

PM15 Front View

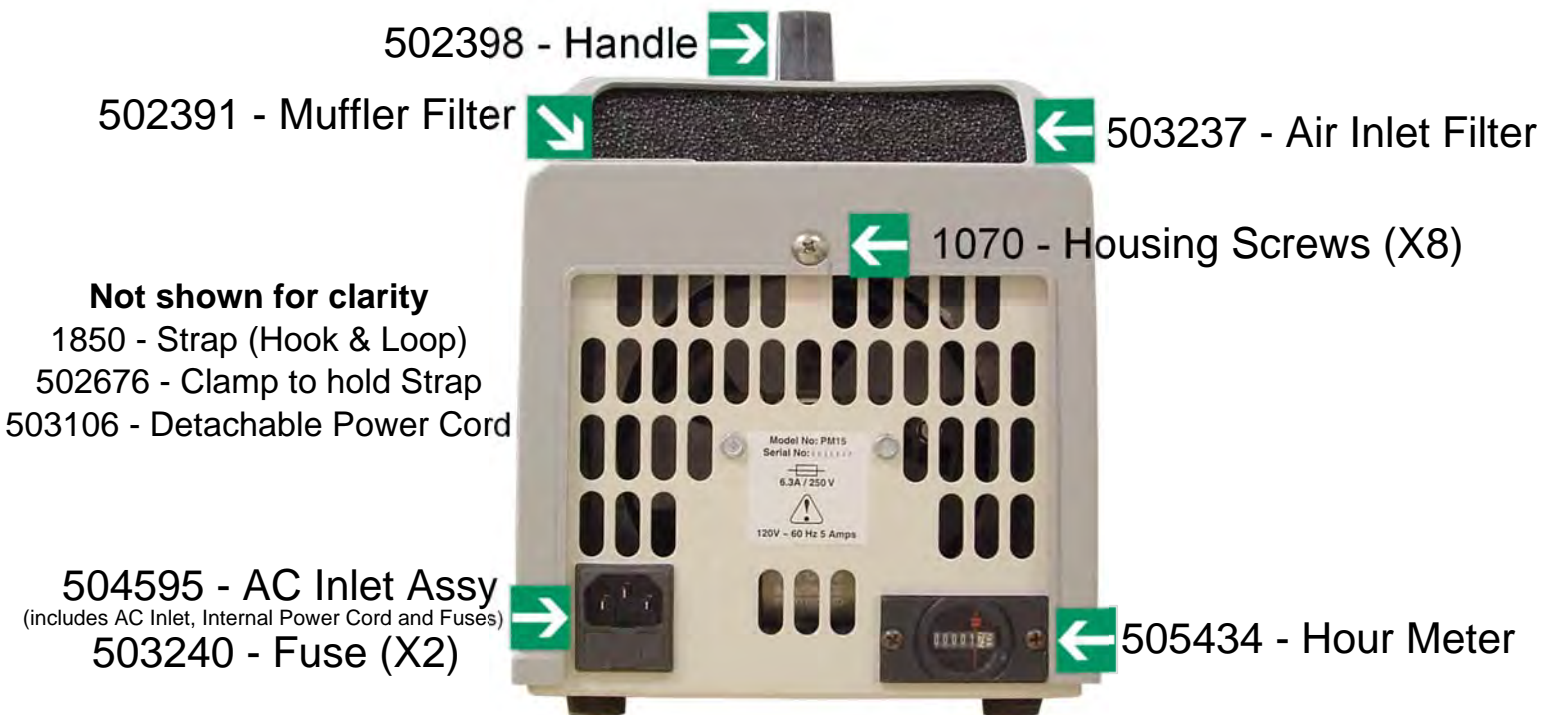

PM15 Rear View



PM15 Internal Top View

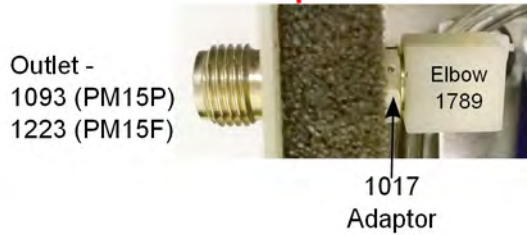
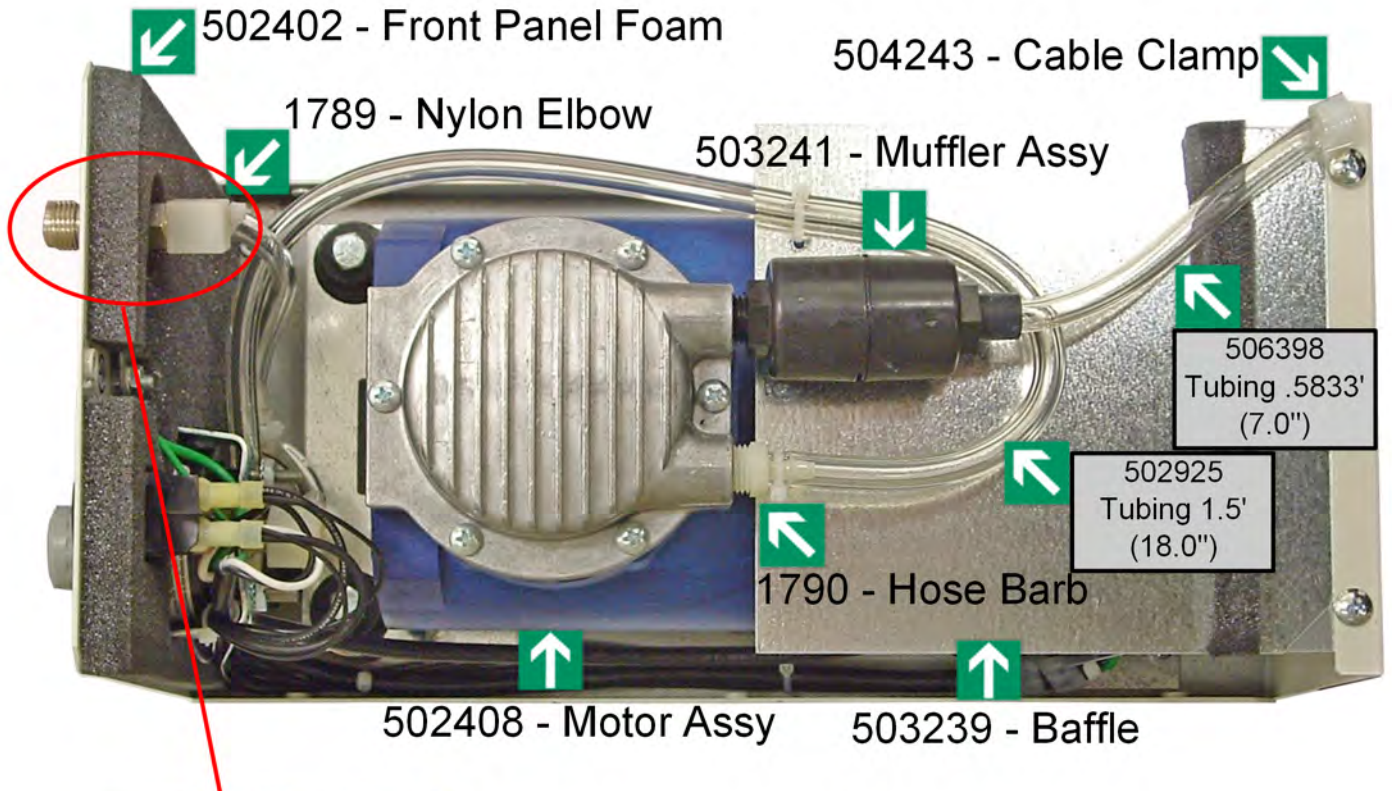

PM15 Internal Right Side View

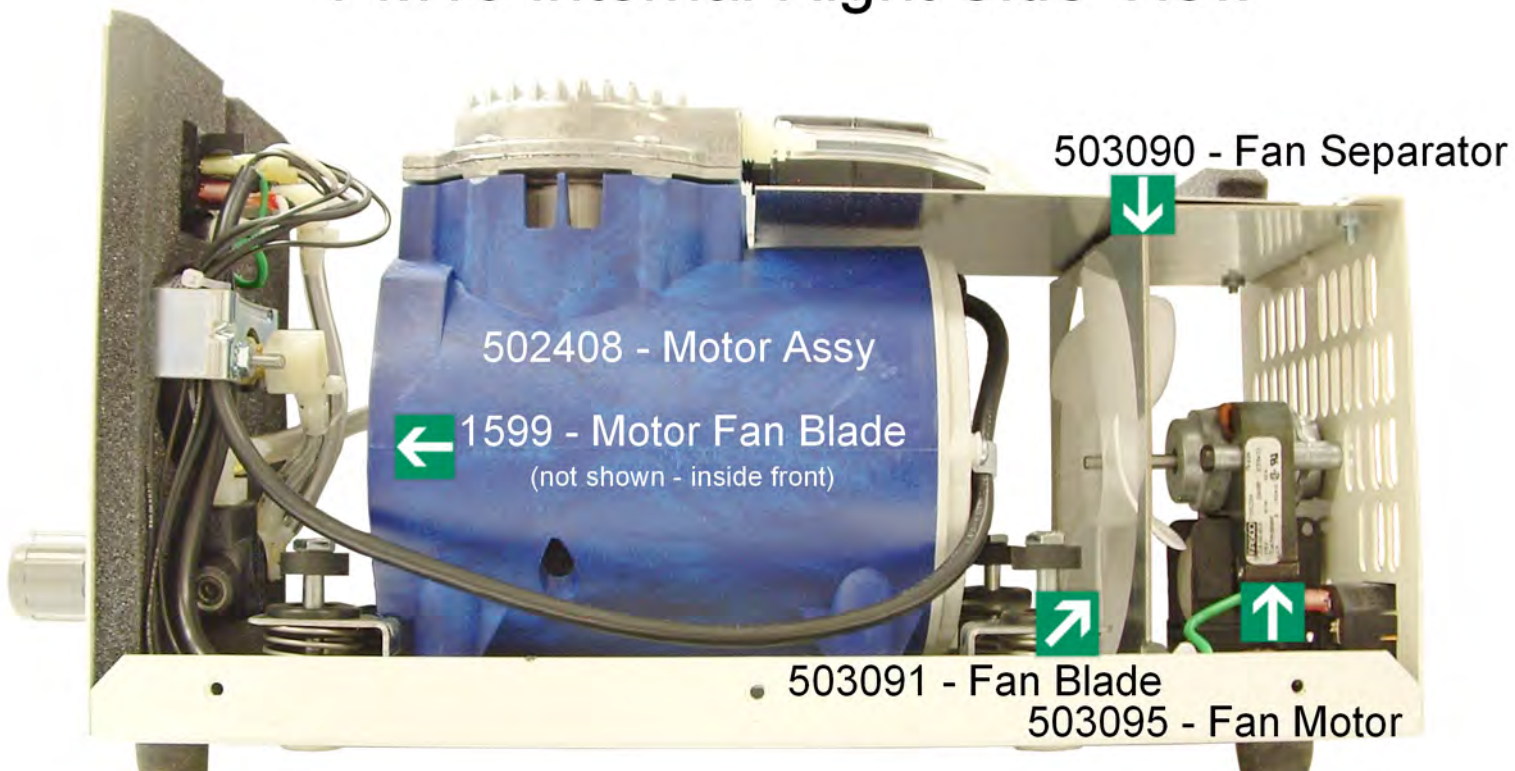

PM15 Internal Left Side View



- ↑ 504085 - Hex Screw
- ↑ 503339 - Rubber Washer
- ↑ 503350 - Rubber Grommet
- ↑ 506928 - Compression Spring

PM15 Internal Front View

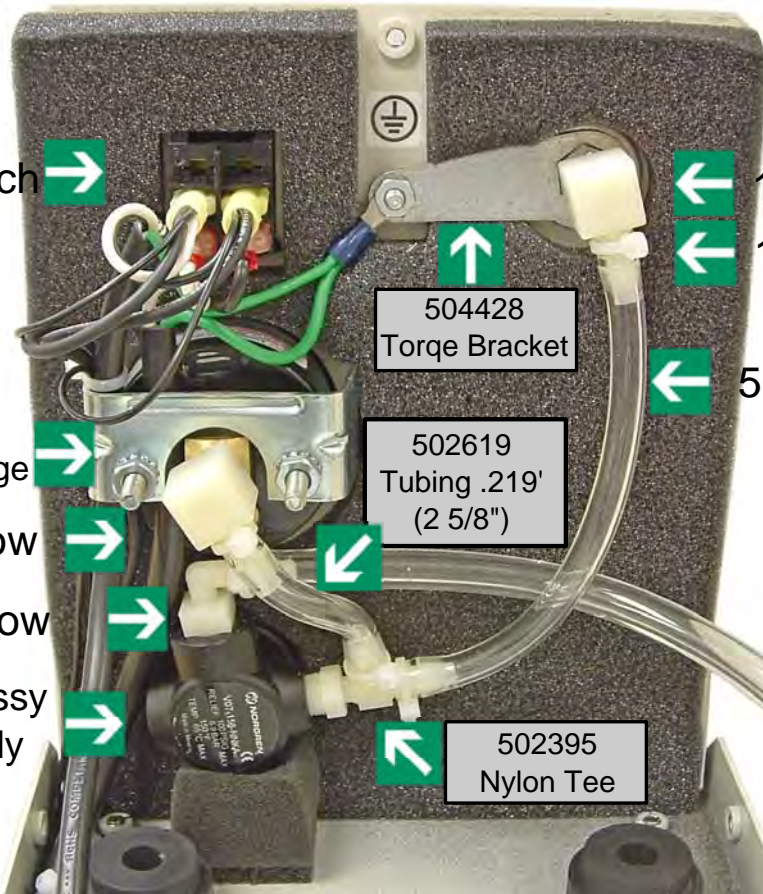

- 1757 - Rocker Switch
- 502591 - Flow Gauge
- 502392 - Pressure Gauge
- 1789 - Nylon Elbow
- 1788 - Nylon Elbow
- 502892 - Regulator Assy
- 1036 - Regulator Only
- ↑ 504428 Torqe Bracket
- ↑ 502619 Tubing .219' (2 5/8")
- ↑ 502395 Nylon Tee
- ↑ 503340 - Rubber Grommet (X4)
- ← 1789 - Nylon Elbow
- ← 1158 - Cable Ties
- ← 502619 - Tubing .4583' (5 1/2")
- ↙ 502925 - Tubing to Compressor 1.5' (18")

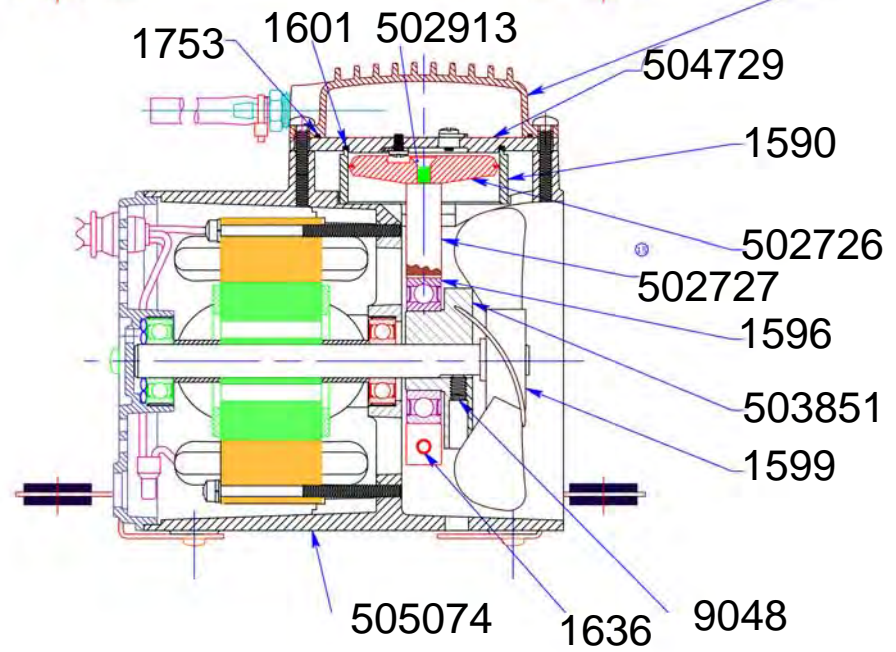
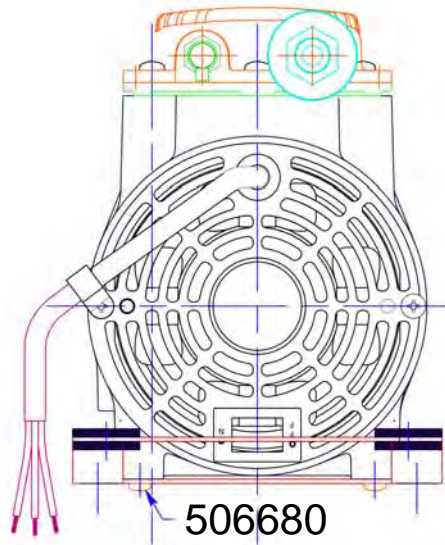
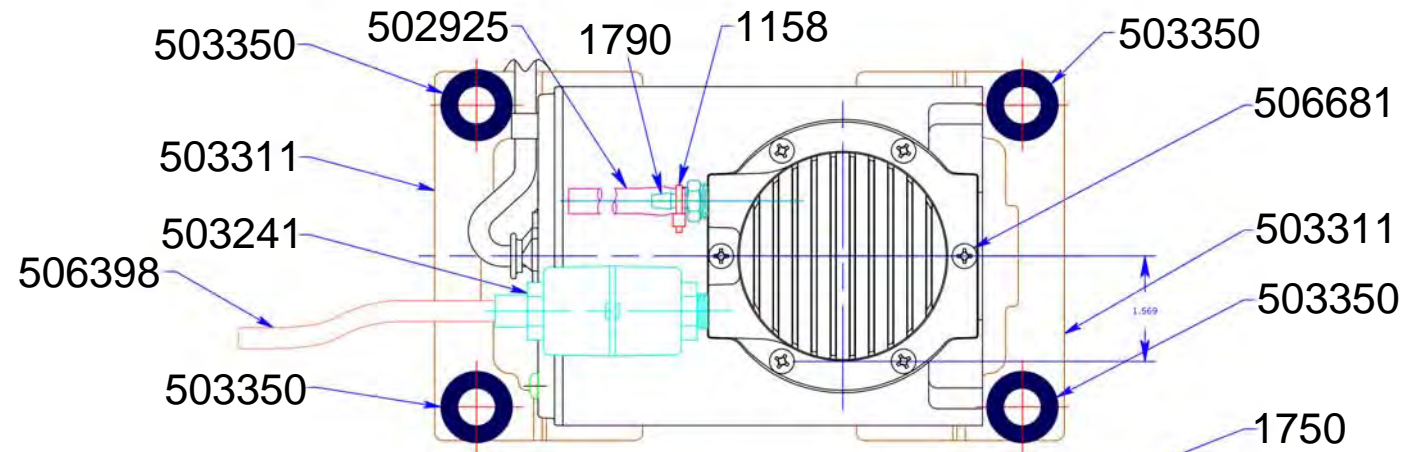

Tubing Diagram PM15

