

PM65 Front View and Accessories

502956
Carry Bag
(Not Shown)

504153
Case Assembly
(includes Case, LED Panel,
Power Switch & Jack, Feet
and Front Label)

503106
AC Power Cord

1955
Suction Tubing

502954
Auto DC Power Cord

503974
Battery Charger

502519-10
800cc Canister (X10)



PM65 Internal Rear View

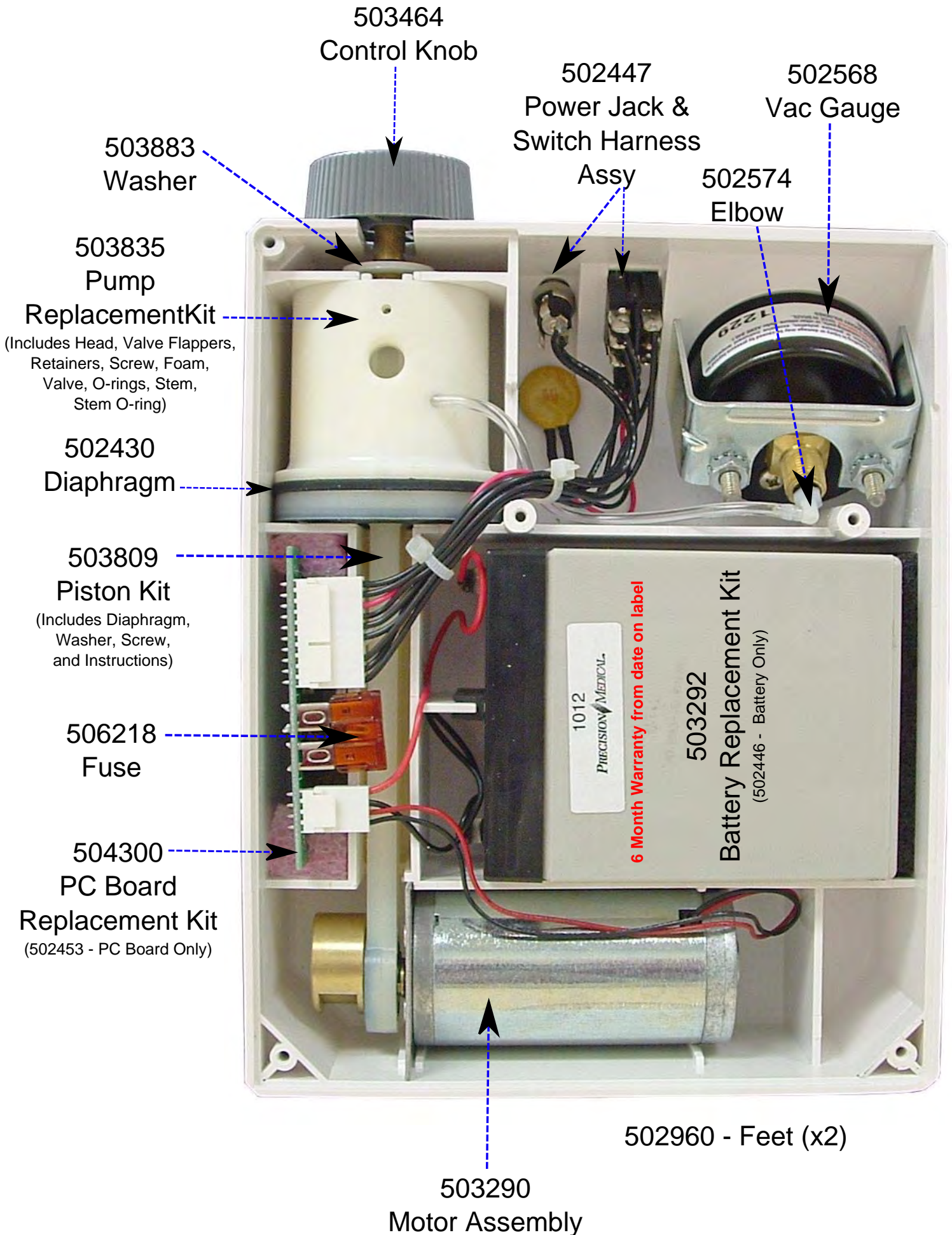

PM65 External Rear View

503293

Hydrophobic Filter Assembly
(506047 Filter Only)

502963

Handle Cover

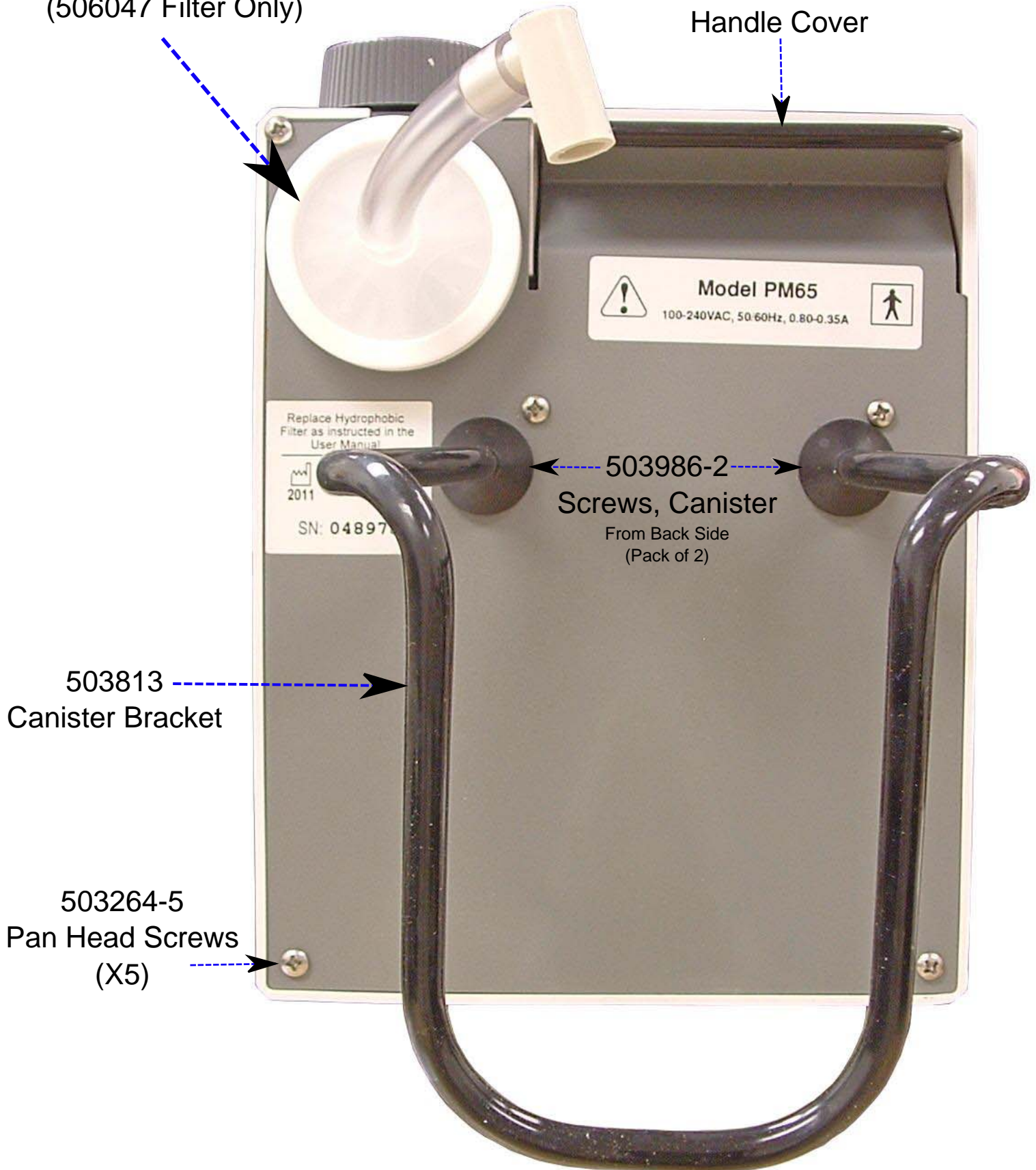

503813
Canister Bracket

503986-2
Screws, Canister
From Back Side
(Pack of 2)

503264-5
Pan Head Screws
(X5)